

### Pallet Fork with Security Chain

**For use with tower cranes:**  
With a security chain as stipulated by government safety regulations. Ensuring safe use in building construction, if the packs are pre-wrapped, bound together or on pallets.

▶ Light weight construction due to the use of high-tensile steel.

### PGE-K

#### Basic Model without Automatic-Centre-of-Gravity-Balance

##### Standard Specifications:

- ▶ Crane eye
- ▶ Height adjustable from 1,050–1,650 mm (41<sup>1</sup>/<sub>2</sub>–65").

▶ Adjustable fork distance from 340–1,000 mm (13<sup>1</sup>/<sub>2</sub>–39<sup>1</sup>/<sub>2</sub>") (external).

▶ Forks have a long taper for optimal engagement.

▶ Security chain with crane eye and chain bag.

▶ Length of forks 980 mm

Type	Fork Dimension mm (in)	Carrying Capacity kg (lbs) at 500 mm (20")	Dead Weight kg (lbs)	Order-Number
PGE 15-K	100 x 40 (4 – 1 <sup>1</sup> / <sub>2</sub> "	1,500 (3,300)	90 (200)	5500.0001
PGE 20-K	120 x 40 (4 <sup>3</sup> / <sub>4</sub> – 1 <sup>1</sup> / <sub>2</sub> "	2,000 (4,400)	115 (255)	5500.0002

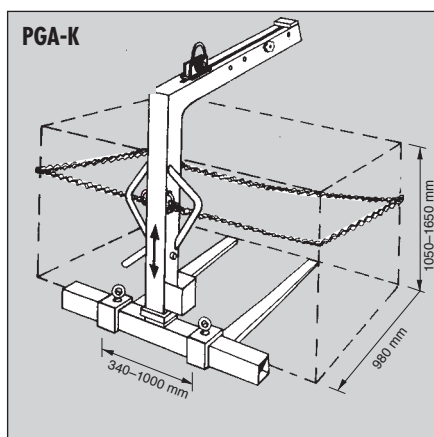

### PGA-K

**Automatic-Centre-of-Gravity-Balance due to a spring-loaded slide mounted on a maintenance free steel-polyamide-slide-bearing.**

##### Standard Specifications:

- ▶ Crane eye
- ▶ Adjustable height from 1,050–1,650 mm (41<sup>1</sup>/<sub>2</sub>–1<sup>1</sup>/<sub>2</sub>").

▶ Adjustable fork distance from 340–1,000 mm (13<sup>1</sup>/<sub>2</sub> – 39<sup>1</sup>/<sub>2</sub>").

▶ Forks have a long taper for optimal engagements.

▶ Security chain with crane eye and chain bag.

▶ Length of forks 980 mm

Type	Fork Dimension mm (in)	Carrying Capacity kg (lbs) at 500 mm (20")	Dead Weight kg (lbs)	Order-Number
PGA 15-K	100 x 40 (4 – 1 <sup>1</sup> / <sub>2</sub> "	1,500 (3,300)	110 (245)	5500.0003
PGA 20-K	120 x 40 (4 <sup>3</sup> / <sub>4</sub> – 1 <sup>1</sup> / <sub>2</sub> "	2,000 (4,400)	120 (265)	5500.0004

Minimum loading weight is approx. 25 % of the load.

Stated minimum loading weight is necessary for the automatic gravity function to work.

DZZ

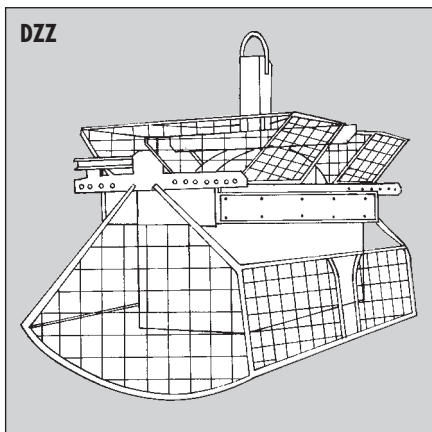

### Roof Tile Clamp DZZ

Suitable for lifting one bundle of roof tiles or concrete roofing slabs (loose, bound or shrink-wrapped).

#### Standard Specifications:

- ▶ Crane eye
- ▶ Exchangeable rubber grippers.
- ▶ Light weight by use of fine grained steel.

- ▶ Automatic release for the fully automatic switch over from "full" to "empty".
- ▶ Protection basket
- ▶ 2 storage compartments for accessories.
- ▶ Adjustable gripping width to 240, 330, 420, 460 and 480 mm.

Type	Gripping Range* W mm (in)	Height E mm (in)	Gripper Length L mm (in)	Carrying Capacity kg (lbs)	Dead Weight kg (lbs)	Order-Number
DZZ	240 – 480 (9½–19")	110 (4¼")	1,150 (45")	200 (440)	73 (160)	5510.0029
Additional price for inlay basket						5510.0004

DZZ-II/2000

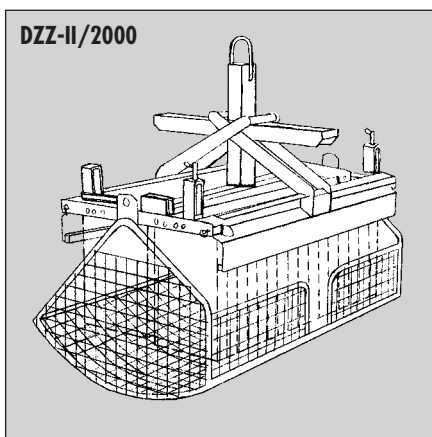

### Roof Tile Clamp DZZ-II/2000

To pick up one or two rows of concrete roof tiles.

For direct charging with truck loading crane on the roof.

The DZZ-II/2000 is equipped with removable central divider, therefore no damaging of the roof tiles when picking up two rows.

#### Standard Equipment includes:

- ▶ Crane eye
- ▶ Exchangeable rubber grippers.
- ▶ Easily removeable central divider.
- ▶ Light weight
- ▶ Automatic release for the fully automatic switch over from "full" to "empty".
- ▶ Protection basket
- ▶ Gripping range widely adjustable.

Type	Gripping Range* W mm (in)	Height E mm (in)	Gripper Length L mm (in)	Carrying Capacity kg (lbs)	Dead Weight kg (lbs)	Order-Number
DZZ-II/ 2000	280 – 770 (11–30¼")	110 (4¼")	1,040 (41")	400 (880)	110 (245)	5510.0011

DEZ-uni

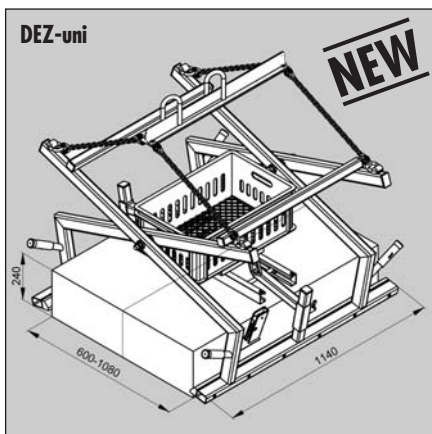

### Roofing Element Clamp DEZ-uni with Security Net

The universal clamp for clay and concrete roof tiles.

With only one device, either two rows of clay roof tiles or two or three rows of concrete roof tiles can be transported quickly and safely on the roof.

Suitable also for large tiles.

**Due to light weight construction and using of high-tensile steels only 75 kg dead weight. That way this sturdy steel device is more light weight than some comparable aluminium devices with the same technical specifications.**

#### With the following standard features:

- ▶ Security net to be hooked into the handles for guiding the clamp.
- ▶ Plastic basket to store the security net. Basket can also be used for transportation of special tile elements on the roof
- ▶ Additional lifting point to hang the loaded clamp on an angle to position the rows of roof tiles directly on the roof. (Not suitable for steep roofs).
- ▶ Ring-eyelet for crane hook
- ▶ Adjustable height-support
- ▶ Automatic release for the fully automatic switch-over from "full" to "empty".
- ▶ Exchangeable rubber grippers as gripping elements.

Type	Gripping Range* W mm (in)	Height E mm (in)	Gripper Length L mm (in)	Carrying Capacity kg (lbs)	Dead Weight kg (lbs)	Order-Number
DEZ-uni	660–1,000 (26–39")	140/210 (5½"/8¼")	1,140 (45)	600 (1,320)	75 (165)	5510.0034

\* The opening width is given as product measurement, however the actual gripping width is bigger to position open tool over the product.

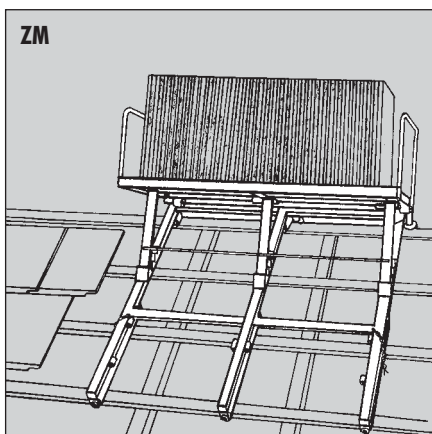

### Ziegelmax ZM

The Ziegelmax moves on maintenance-free rollers, using in the existing rafters or supports.

▶ Light weight, due to its aluminium construction.

**ZM** to pick up two rows of roof tiles.

▶ Adjustable for roof slopes from 15° to 55°.

**ZM-G** suitable for special large roof tiles.

Type	Storage Surface mm (in)	Carrying Capacity kg (lbs)	Dead Weight kg (lbs)	Order-Number
<b>ZM</b>	1,350 x 750 (53 x 29 1/2")	400 (880)	30 (65)	<b>5510.0030</b>
<b>ZM-G</b>	1,350 x 900 (53 x 35 1/2")	420 (930)	34 (75)	<b>5510.0032</b>

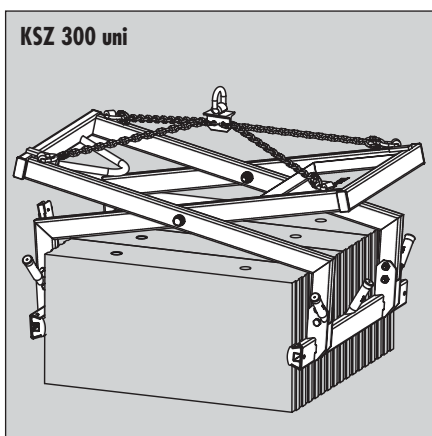

### Limestone Clamp KSZ 300 uni

Especially designed for the transport of limestone elements by a tower crane. The clamp is variably gripping all packs up to the indicated opening width safely. An adjustment of the gripping width is no longer necessary. The security net can be hung easily underneath the load.

#### Standard Specifications:

(Safety net also suitable for blocks with height 625 mm).

▶ Crane eye

▶ Safety net

▶ Fully automatic release from "full" to "empty".

▶ Rubber metal bars as gripping elements (bright model – no marks left on visible brick work).

Type	Gripping Range mm (in)	Height E mm (in)	Gripper Length L mm (in)	Carrying Capacity kg (lbs)	Dead Weight kg (lbs)	Order-Number
<b>KSZ 300 uni</b>	750 - 1,000 (29 1/2 - 39")	300 (11 3/4")	1,000 (39")	1,250 (2,750)	110 (245)	<b>5520.0033</b>

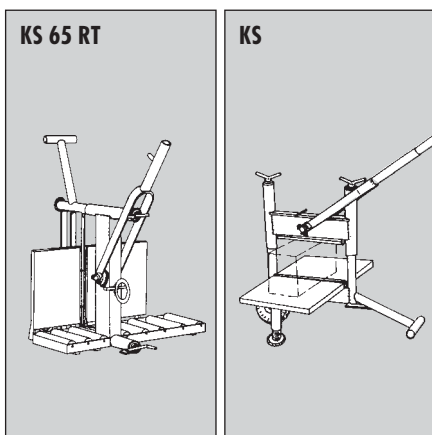

### Limestone Cutter KS

For splitting limestone with a cutting table and support on both sides.

sawing, thus saving a considerable amount of time and money.

Stones can also be split diagonally.

▶ The machine can be placed directly at site. Easily adjustable cutting height.

▶ With crane eye for lifting by crane.

▶ Both upper and lower blades have four cutting edges ensuring long life.

▶ **The KS 65 RT comes complete with roller track and cutting table to make easy work of splitting larger blocks.**

▶ No more time consuming and expensive

Type	Cutting Width mm (in)	Cutting Height mm (in)	Dead Weight kg (lbs)	Order-Number
<b>KS 43 UT</b>	430 (17")	10 - 400 (1/2 - 15 3/4")	75 (165)	<b>5530.0001</b>
<b>KS 65 UT</b>	650 (25 1/2")	10 - 400 (1/2 - 15 3/4")	95 (210)	<b>5530.0002</b>
<b>KS 65 RT</b>	650 (25 1/2")	10 - 400 (1/2 - 15 3/4")	125 (275)	<b>5530.0003</b>

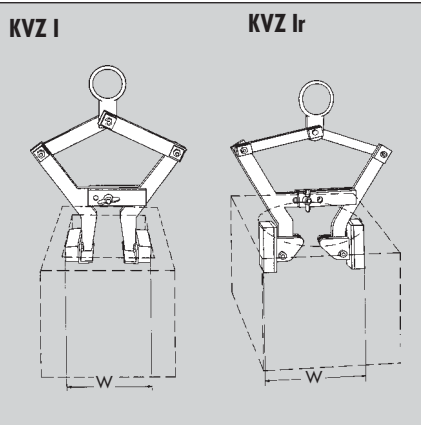

### Chimney Section Clamp KVZ

For chimney sections with an internal width of 20 – 30 cm.

Type	Gripping Range W mm (in)	Gripper Length L mm (in)	Carrying Capacity kg (lbs)	Dead Weight kg (lbs)	Order-Number
<b>KVZ I</b>	200 – 300 (7 <sup>3</sup> / <sub>4</sub> – 11 <sup>3</sup> / <sub>4</sub> "	110 (4 <sup>1</sup> / <sub>4</sub> "	150 (330)	5.5 (12)	<b>5540.0001</b>

For round chimney sections with an internal width of 20 – 30 cm.

Type	Gripping Range W mm (in)	Gripper Length L mm (in)	Carrying Capacity kg (lbs)	Dead Weight kg (lbs)	Order-Number
<b>KVZ Ir</b>	200 – 300 (7 <sup>3</sup> / <sub>4</sub> – 11 <sup>3</sup> / <sub>4</sub> "	120 (4 <sup>3</sup> / <sub>4</sub> "	150 (330)	6 (13)	<b>5540.0002</b>

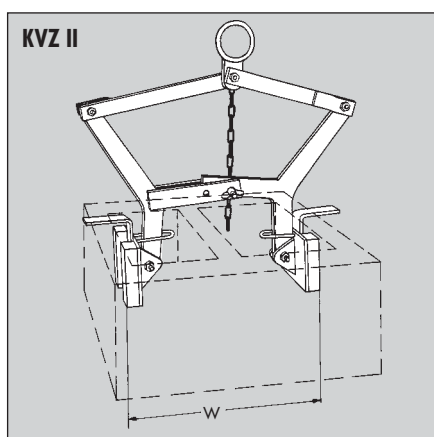

### Chimney Section Clamp KVZ II

For chimney section with two-square or round holes.

Type	Gripping area W mm (in)	Gripper Length L mm (in)	Carrying Capacity kg (lbs)	Dead Weight kg (lbs)	Order-Number
<b>KVZ II</b>	340 – 640 (13 <sup>1</sup> / <sub>2</sub> – 25 <sup>3</sup> / <sub>4</sub> "	140 (5 <sup>1</sup> / <sub>2</sub> "	250 (550)	15 (32)	<b>5540.0005</b>

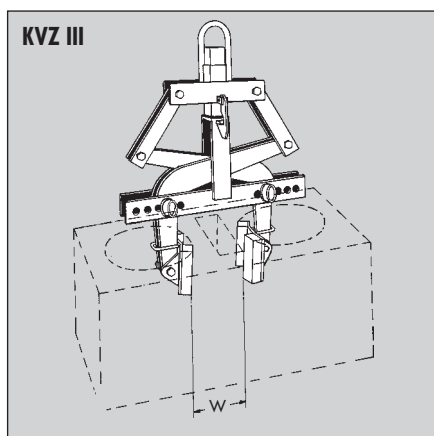

### Chimney Section Clamp KVZ III

For two- or three-round-holed chimney sections.  
Grips at the middle section.

Type	Gripping Range W mm (in)	Gripper Length L mm (in)	Carrying Capacity kg (lbs)	Dead Weight kg (lbs)	Order-Number
<b>KVZ III</b>	60 – 350 (2 <sup>1</sup> / <sub>4</sub> – 13 <sup>3</sup> / <sub>4</sub> "	150 (6")	500 (1,100)	38 (82)	<b>5540.0010</b>

### Laying Clamp for Hollow Core Slabs VZ-D

Suitable for gripping and laying hollow core slabs. Opening range suitable for width of slabs 1,200 mm. Mostly this type of grab is used as a pair, suspended on a spreader bar.

#### Standard equipment:

- ▶ Lifting eye for attaching to crane hook.
- ▶ Automatic release for fully automatic switch-over from "full" to "empty".
- ▶ Handles to guide the clamp.
- ▶ Security chain for the use with the crane.

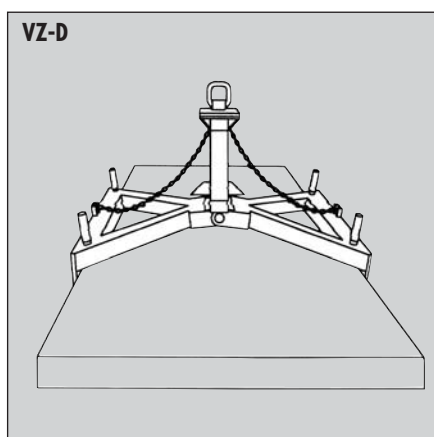

Type	Gripping Range W mm (in)	Gripper Length L mm (in)	Carrying Capacity kg (lbs)	Dead Weight kg (lbs)	Order-Number
<b>VZ-D-2,5</b>	1,200 (47")	1,000 (39")	2,500 (5,500)	106 (230)	<b>5740.0036</b>
<b>VZ-D-6</b>	1,200 (47")	1,000 (39")	6,000 (13,200)	230 (500)	<b>5740.0037</b>

Versions more favourable in price, without automatic release, with manual locking, on request.

Spreader bar for laying of long and heavy elements on request.