

Probst gets things moving –
innovative, efficient and ergonomic



Building Material Plants – In-plant Handling

13

Special Devices



Broadest range of handling tasks – we have the solution

13

SPECIAL DEVICES

Stack Rotating Clamp WG-P

Turns packs of building hollow blocks by 180° so that the blocks do not have to be turned on site by hand (turning range 360° endless).

- Can also be used for stacking products produced on an egg layer machine
- The large opening range means many other products can also be turned quickly and safely through 360°
- The dimensions of the rubber grippers depend on the range of goods to be lifted
- Forklift connecting hoses optionally available



Type	Opening Width W mm (in)	Working Load Limit WLL kg (lbs)	Dead Weight kg (lbs)	Order-Number
WG-P	300 – 1,300 (11¾ – 51")	3,000 (6,600)	1,000 (2,200)	5740.0006



Hydraulic Pallet Turning Device WT-P

Suitable to pick up and turn a complete pack on a pallet by 180°. Turning speed approx. 15 seconds for 180° rotation.

Standard specifications:

- Electro hydraulic power pack, ready to be plugged into the electrical power supply
- Integrated fork sleeves for internal transport of the complete unit within the factory
- Radio remote control for “gripping” and “rotation”

Type	Pack Dimension mm (in)	Working Load Limit WLL kg (lbs)	Dead Weight kg (lbs)	Order-Number
WT-P	1,300 x 1,000 x 1,000 (51" x 39" x 39")	3,000 (6,600)	1,300 (2,850)	5740.0137
Lower price without remote control				on request

Mould Turning Device FW-1

Specially designed for maintenance and repairs of the high quality moulds for a concrete block machine.

- With exchangeable retainer for the different moulds
- Electrical 360° continuous rotation by geared motor and bilateral mounting
- With retractable shafts for implementation with the forklift
- Equipped with elec-tro-mechanical drive ready for plug in

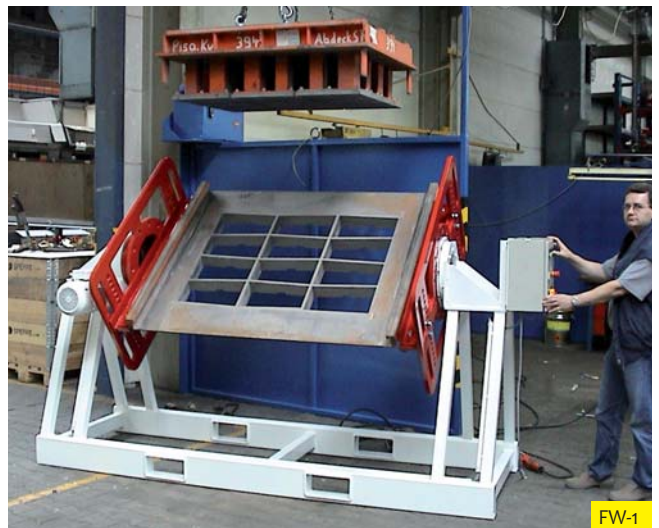

Type	Working Load Limit WLL kg (lbs)	Dead Weight kg (lbs)	Order-Number
FW-1	2,000 (4,400)	1,000 (2,200)	5740.0087

Hydraulic Stonesplitter SSP-300-600-25

Compact, powerful and safe hydraulic splitter for concrete elements. The best solution for small series, tests and special parts.

- Universally suitable, can be carried inside the factory via forklift
- High splitting force, adjustable up to 25 t (55,100 lbs)
- Simple operation, stone is easily moved by roller conveyor
- Highest working safety thanks two-hand operation and a transparent safety curtain
- Adjustable, retractable stop

Standard specifications:

- Hydraulic power pack, electric control box, splitting unit, everything integrated into the main frame
- Electric cable with plug for 16 Ampere 3 phase socket
- Hardened special blades
- Integrated tool box



SSP-300-600-25

Type	Measurements L x B x H mm (in)	max. Splitting Force t (t)	max. Width of Element mm (in)	Height of Element mm (in)	Dead Weight kg (lbs)	Order- Number
SSP-300-600-25	1,800 x 1,050 x 1,600 (71" x 41" x 63")	25 (25)	600 (23½)	50 – 300 (2 – 11¾")	860 (1,900)	5800.0001



AL-90/NSH-40

Hydraulic Block Cutter AL-90/NSH-40

The environmentally friendly alternative to block sawing.

- Snap large blocks at the touch of a button, entirely without dust, noise or wastewater
- With fixed-mounted, split triangular reversible carbide blade
- particularly suitable for natural stones such as granite with less than 4 mm height difference in thickness

Type	Splitting Force t	Blade	Cutting Length mm (in)	Cutting Height mm (in)	Dead Weight kg (lbs)	Surface	Order- Number
AL-90/NSH-40	40	rigid	400 – 900 (15¾ – 35½")	40 – 370 (1½ – 14½")	500 (1,100)	Painted	5120.0054

Limestone Cutter AL-90/KSH-20

The hydraulic powerhouse with high splitting force.

- Cut large blocks at any angle in fractions of a second
- Equipped with a roller guide and tilting unit
- Splitting force 20 t
- Holder for fork tines for quick transportation
- Drive: electro-hydraulic, 220 V

Type	Splitting Force t	Cutting Length mm (in)	Cutting Height mm (in)	Dead Weight kg (lbs)	Surface	Order- Number
AL-90/KSH-20	20	400 – 900 (15¾ – 35½")	40 – 370 (1½ – 14½")	400 (880)	Painted	5120.0053



AL-90/KSH-20

The clamp for rational sorting

13

SPECIAL DEVICES

Sorting Clamp ASZ / ASZ-R

This universal outsourcing clamp has a wide adjustable opening width and can be used for a wide range of products.

There are two different variations:

1. **ASZ** for the efficient outsourcing of concrete steps, kerb stones and similar
2. **ASZ-R** for the handling of sewerage elements.
The grippers are prism-shaped to grip the round contour of the rings

Standard Specifications:

- Lifting eye for attaching to crane hook
- Handle with turning range 90° depending on space
- Exchangeable rubber metal bars, to suit the requirements
- Automatic release for fully automatic switch-over from “full” to “empty”

Please note: Designed and suitable to grip single stones or elements only. This is not the proper equipment for handling a complete row of stones.



Type	Pack width W mm (in)	Inside Height mm (in)	Gripper Length L mm (in)	Working Load Limit WLL kg (lbs)	Dead Weight kg (lbs)	Order-Number
ASZ ①	600 – 1,200 (23½ – 47")	120 (4¾")	200 (7¾")	250 (550)	26 (55)	5310.0259-005

Additional adapters for ASZ
(to be mounted on the basic grippers of the outsourcing clamp)

A-50			50 (2")			4310.0376
A-100			100 (4")			4310.0377
ASZ-R ①	∅ 620 – 1,200 (23½ – 47")	100 (4")	300 (11¾")	250 (550)	34 (75)	5310.0281-003

① Durable surface protection by galvanizing

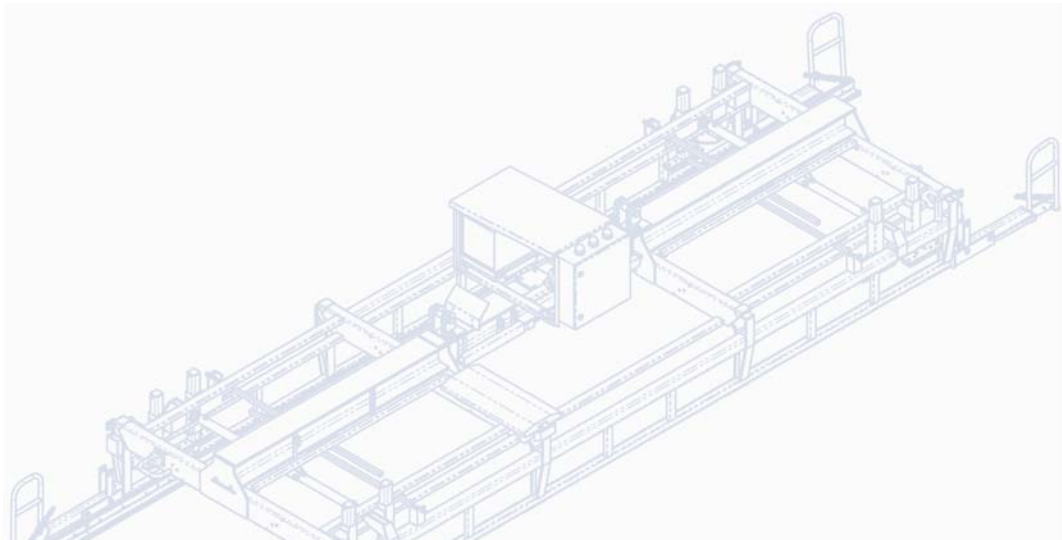

13.1

Special Devices – Customer-specific solutions



Examples for customer-specific solutions

13.1

Hydraulic grab for gripping 1 – 3 T-profile concrete beams

For T-profile parts with a max. length of 8,000 mm and a max. total weight of 1,500 kg.

- With flange plate for mounting a hydraulic rotator

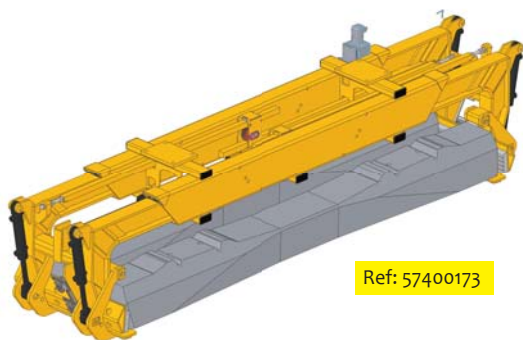

Ref: 57400173



Ref: 57400166

Hydraulic sleeper grab – for gripping 2 concrete sleepers at the same time

For concrete sleepers Type B70 with 1,800 – 2,600 length. Working Load Limit 1,000 kg.

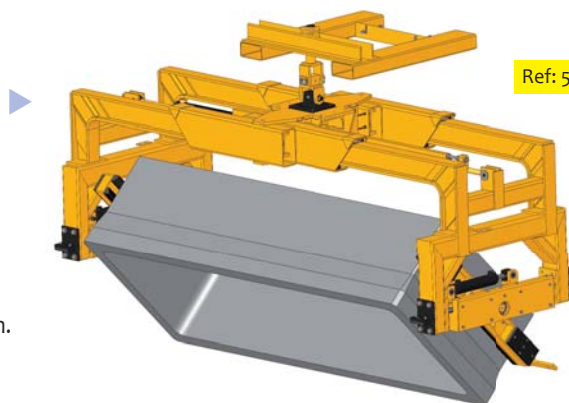

Ref: 57400170

Hydraulic grab – for demolding and turning concrete elements (burial chambers)

Concrete elements up to a max. weight of 1,000 kg produced upside down. Using this hydraulic grab, these elements can be removed from the mold without damage, turned hydraulically through 180 degrees and set down in the correct installation position.

- With fork sleeves for lifting forks

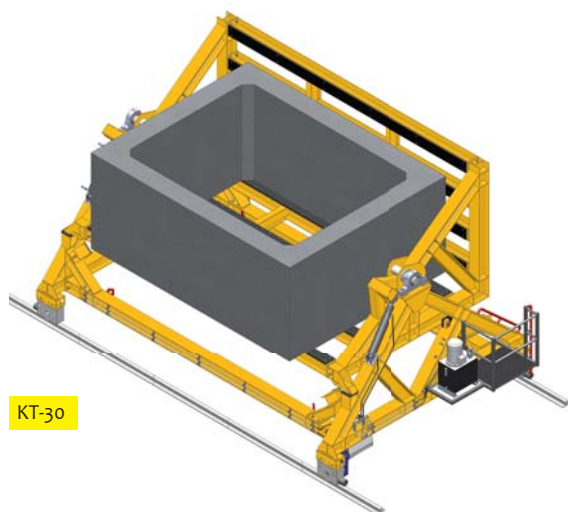

KT-30

Hydraulic Tilting Table KT-30 – for Tilting rectangular concrete box culverts

Suitable for tilting rectangular concrete chambers through 90 degrees, max. load capacity 30 t

- Stored on a base frame, rotational drive via hydraulic cylinders
- Special version with undercarriage

Vacuum turning device – for demolding and simultaneously turning L-stones

Using vacuum suction power, L-stones up to a max. weight of 1,800 kg can be removed from their mold, turned through 180 degrees and set down precisely.

Ref: 57600043



Customer-specific solutions

Please clarify technical specifications such as opening widths, heights, working load limits etc.

Send us your requirement profile: we will find the right solution!

Concrete Pipe Handling System RUS

Hydraulic gripping system suitable for pipes with an inside diameter of 250 mm to 1200 mm.

- Different clamp-bottom parts for different diameters and numbers of pipes can be picked up by the top part via a bayonet catch



RUS



RUS



RUS

Universal Pipe Grab System URS-ST

Hydraulically operating gripper for all pipes with gripping range of 250 – 1200 mm.

- The bottom parts of the Grab for various gripping ranges are gripped by the top part like a bayonet catch
- Turning range 90° for loading the truck lengthwise or crosswise



URS-ST



Ref: 57400100

Setting-Up Device for Noise Protection Walls

Hydraulic operated setting up device for noise protection walls up to max. 4 t.

- With radio remote control for the following functions: grabbing, setting-up, adjustable centre of gravity and distance control
- The wall-elements are taken out of a mould, hydraulically turned by 90° and set down vertically on transport palettes

Laying Clamp for Hollow Core Slabs VZ-D

Mechanical clamp in various special designs as desired by the customer.

- With automatic release for the fully automatic switch-over from “full” to “empty”
- Easily attachable and removable safety chains with deposit tray
- Working load limit up to 6 t



VZ-D

13.1

Special grab for beams

Hydraulically operated forklift attachment grab for handling several concrete beams at once.

- Mainly used for clearing the production space
- Here in conjunction with a crane boom with extension telescoping



Special grab for beams



FTZ-UNI-50

Grab for Prefabricated Concrete Products FTZ-UNI-50 with Spreader Bar

Once more proof of the advantages of the modular design system of Probst products:

- Once more proof of the advantages of the modular design system of Probst products: Two mechanical operated standard products, FTZ-UNI-50, linked with a spreader bar. Concrete elements of up to 8 t are handled quick, easy and with care

Customer-specific solutions

Please clarify technical specifications such as opening widths, heights, working load limits etc.

Send us your requirement profile: we will find the right solution!

Concrete Highway Divider Clamp BSZ

Hydraulic concrete highway divider clamp in special design for fast and efficient handling of such concrete highway divider elements.

- Special design twofold
- Special design fivefold

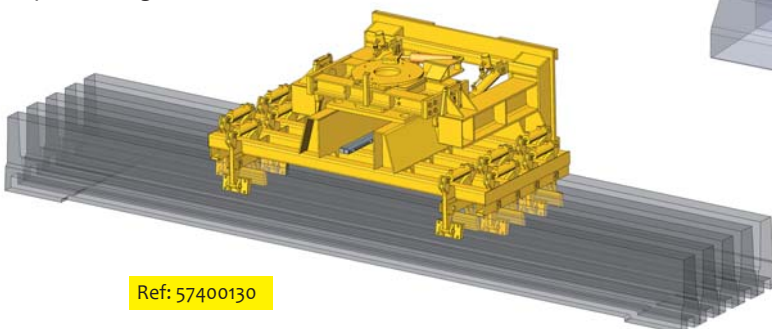

Ref: 57400130

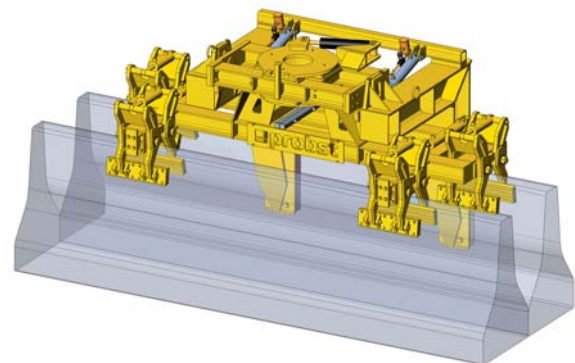

Ref: 57400154

Concrete Sleeper Grab

Allows simultaneous grabbing and application of a whole layer of railway sleepers.

- For loading rail transport systems for track construction
- Grab range respectively for sleeper lengths 220 cm, 240 cm, 250 cm, 260 cm and 270 cm
- With 2 suspension points for 2 crane hooks
- Working Load Limit 12,500 kg



Ref: 57400146



VT-6000-D

Vacuum Spreader Bar VT-6000-D

Vacuum Spreader Bar VT with diesel engine for generating the vacuum.

- Lifting equipment can be a fork lift truck or a crane
- Equipped with 4 adjustable 1500 kg suction plates

Vacuum Lifting Device SH-1000-MINI-H with Spreader Bar

Based on the modular design system we can easily combine cost efficient customized Vacuum Lifting Devices for Fork Lift Trucks. It is specially designed for internal transportation of large-sized concrete slabs.

- A standard version of the Vacuum Lifting Device SH-1000-MINI-H is equipped with Fork sleeves, hydraulic rotor, and a spreader bar with 4 standard suction plates
- The suction and releasing process is controlled from the driver seat in the cabin

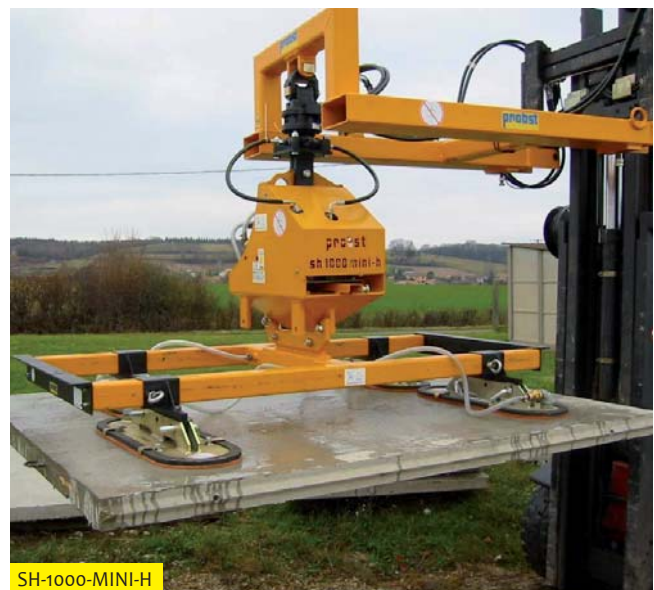

SH-1000-MINI-H

Fork Lift Grab STAZ (AKZ) -750 with rotating grippers

This specially designed Forklift Attachment Grab is used to grip several box sections and rotate them by 180 degree.

- This box sections are casted upside down and have to be rotated after production for storage, shipment and installation in order to eliminate the mold distance between each box, a special crossbar is fixed to the rotating grippers
- This crossbar is used to shift the box sections towards one another by using the hydraulic function of the sideshift of the forklift



STAZ (AKZ) -750



Vacuum Load-Suction Device with 180° Turning Unit

Vacuum Load-Suction Device with 180° Turning Unit

Vacuum load-suction device for internal use at stripping and packaging of windowsills.

- The windowsills are overhead produced, taken off the form and turned by 180° for further process or packaging

Special Laying Grab for Noise- Protection-Elements

Efficient installation of noise-protection-elements between rail-tracks and railway sleepers.

- The grab does the exact positioning of the 4 elements as well as the precise installation



Ref: 57400059

Pneumatic Rotating Clamp P-WG

With many production processes for concrete elements, they must be turned by 90 degrees or 180 degrees for demolding and for further processing.

- Clamping and turning by 90 or 180 degree is pneumatically operated. Mostly used for handling at the sandblasting machine or for demolding
- See also pneumatic Rotating Clamp on page 10

The Pneumatic Rotating Clamp can be individually adjusted to your requirement profile.



P-WG



P-WG

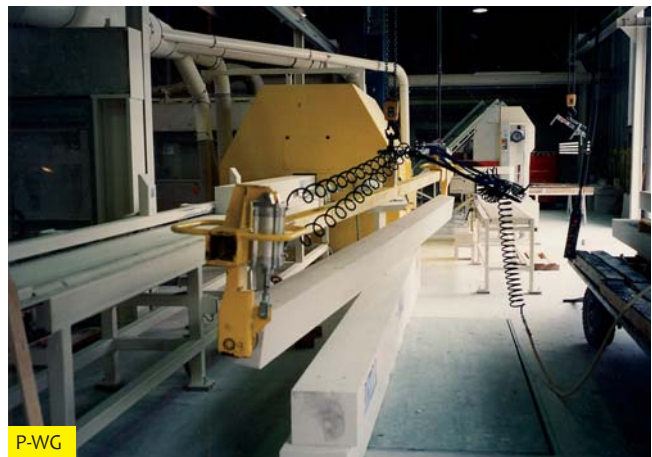

P-WG

Mechanical Mould Clamp for Steel Moulds

Mechanical clamp for positive handling of steel moulds for railway sleepers.

- Includes height-adjustable support with centring aid
- Fully automatic trip mechanism for switch-over from „full“ to „empty“
- With lifting eye for crane hook

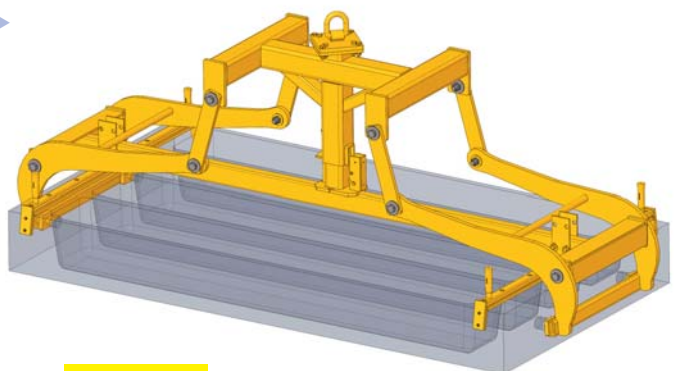

Ref: 57400177

Hydraulic clamp for stacked ceiling elements

Pre-packed stacks of ceiling elements are grabbed and applied/loaded with the gantry crane in a single step.

- Individual ceiling elements can also be grabbed and compiled into stacks
- Length of the clamp jaws can be adjusted
- The suspension point can be moved by motor so that the ceiling elements hang exactly horizontally

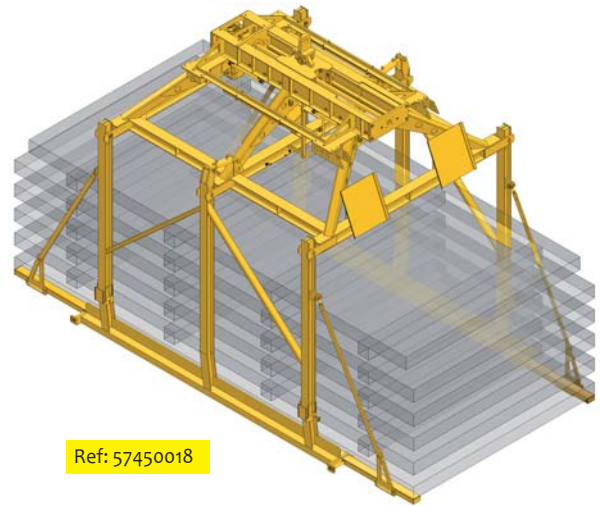

Ref: 57450018

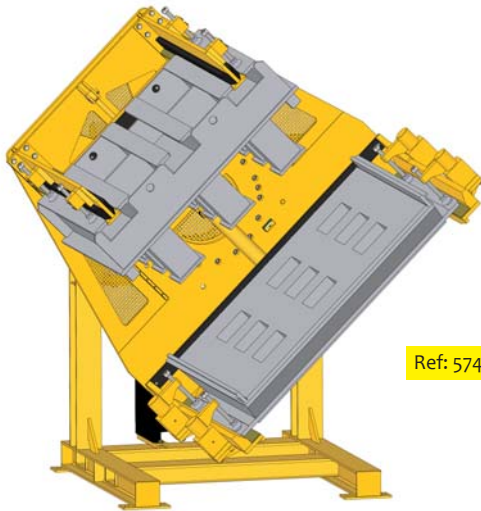

Ref: 57400142

Lifting and turning device for concrete block moulds

Suitable for maintenance and repair work on tops and bottoms of concrete block moulds in the concrete plant.

- Mold box and top part with shoes can be locked separately and turned by 360 degree

Forklift grab with vacuum turning unit for concrete elements

The concrete elements freshly removed from the mould are picked up gently by vacuum suction plates and rotated by 180 degree.

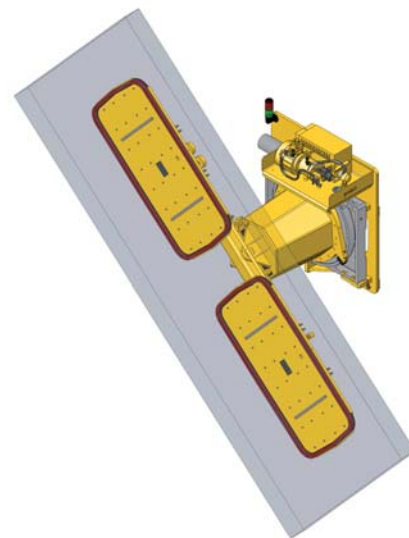

Ref: 57600027

Ref: 57400145

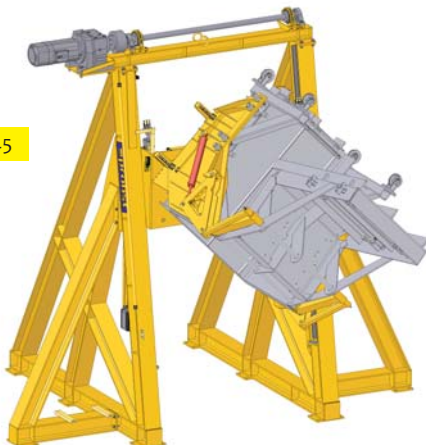

Lifting and turning station for the production of wall segments

Wall segments are produced in large quantities in an automated process.

- In this station, the moulds are picked up with the hardened wall segments, lifted, and turned by 180 degrees to remove the moulds from the concrete elements

Automatic packetising clamp for light shaft elements

The light shaft elements are picked from the production tray, tilted by 90 degrees and placed on a transport pallet.

- For a better nesting option, the entire clamp unit can be turned by 180 degrees

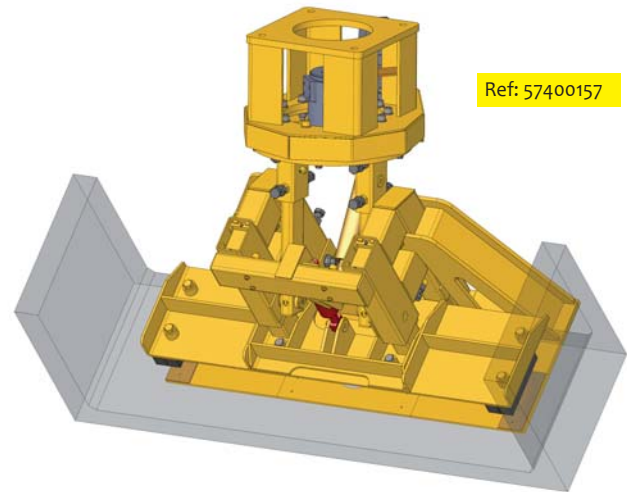

Ref: 57400157



Ref: 57000157

Fork Lift Grab Tübbing

These tunnel elements are clamped gently and can then be transported with the forklift.

- Attachments also possible for multiple transport

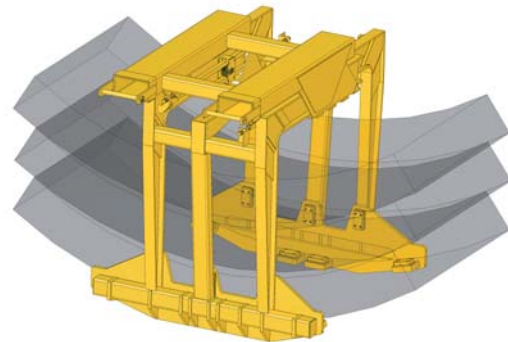

Forklift grab for moving special cladding elements in a tunnel

The extremely fragile concrete elements are clamped with vacuum suction plates, hydraulically turned by 90 degrees, then positioned with millimetre precision in front of the tunnel wall.

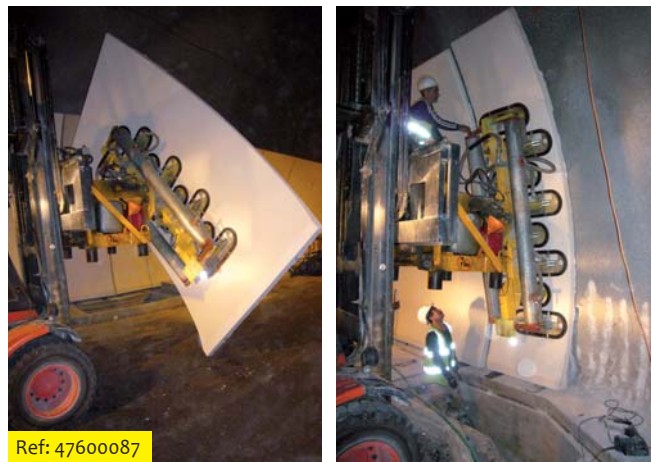

Ref: 47600087

**Send us your requirement profile:
we will find the right solution!**

Probst GmbH
Gottlieb-Daimler-Straße 6
71729 Erdmannhausen, Germany
Phone +49 7144 3309-0
Fax +49 7144 3309-50
info@probst-handling.com

www.probst-handling.com

Our branch in United Kingdom

Probst Handling Equipment
Unit 2 Fletcher House, Stafford Park 17
Telford, Shropshire, TF3 3DG
Phone + 44 1952-292733 • Fax + 44 1952-290480
info@probst-handling.co.uk
www.probst-handling.co.uk



Site equipment



Tile Handling



Truck Crane Attachments



Service



We will gladly advise you.

MACHINETOOL

Oy Machine Tool Co
Teerikukonkuja 4, 00700 Helsinki
Finland
www.machinetool.fi