



# DATASHEET

SG BASE PART AND SG SILICONE TOOLS

V1.0

# 1 Datasheet

## 1.1 SG Base Part

General Properties	Minimum	Typical	Maximum	Unit
Total spindle stroke	11 0.43	-	40 1.57	[mm] [inch]
Spindle position resolution	-	0.1 0.0039	-	[mm] [inch]
Spindle force	-	-	380	[N]
Spindle speed	-	-	37 1.46	[mm/s] [inch/s]
Gripping time* (SG-a-H)	-	-	32	[grip/min]
SG-tool attachment mechanism	Smart lock			
Motor	Integrated, electric BLDC			
IP Classification	IP67			
Dimensions (H x Ø)	84 x 98 3.3 x 3.85			[mm] [inch]
Weight	0.77 1.69			[kg] [lb]

\*Gripping time is tool depended. See the separate SG Datasheet for the tool specific gripping time.

Operating Conditions	Minimum	Typical	Maximum	Unit
Power supply	20	24	25	[V]
Current consumption	45	-	600	[mA]
Operating temperature	0 32	- -	50 122	[°C] [°F]
Storage temperature	0 32	- -	60 140	[C] [F]
Relative humidity (non-condensing)	0	-	95	[%]
Calculated MTBF (operating life)	30.000	-	-	[Hours]

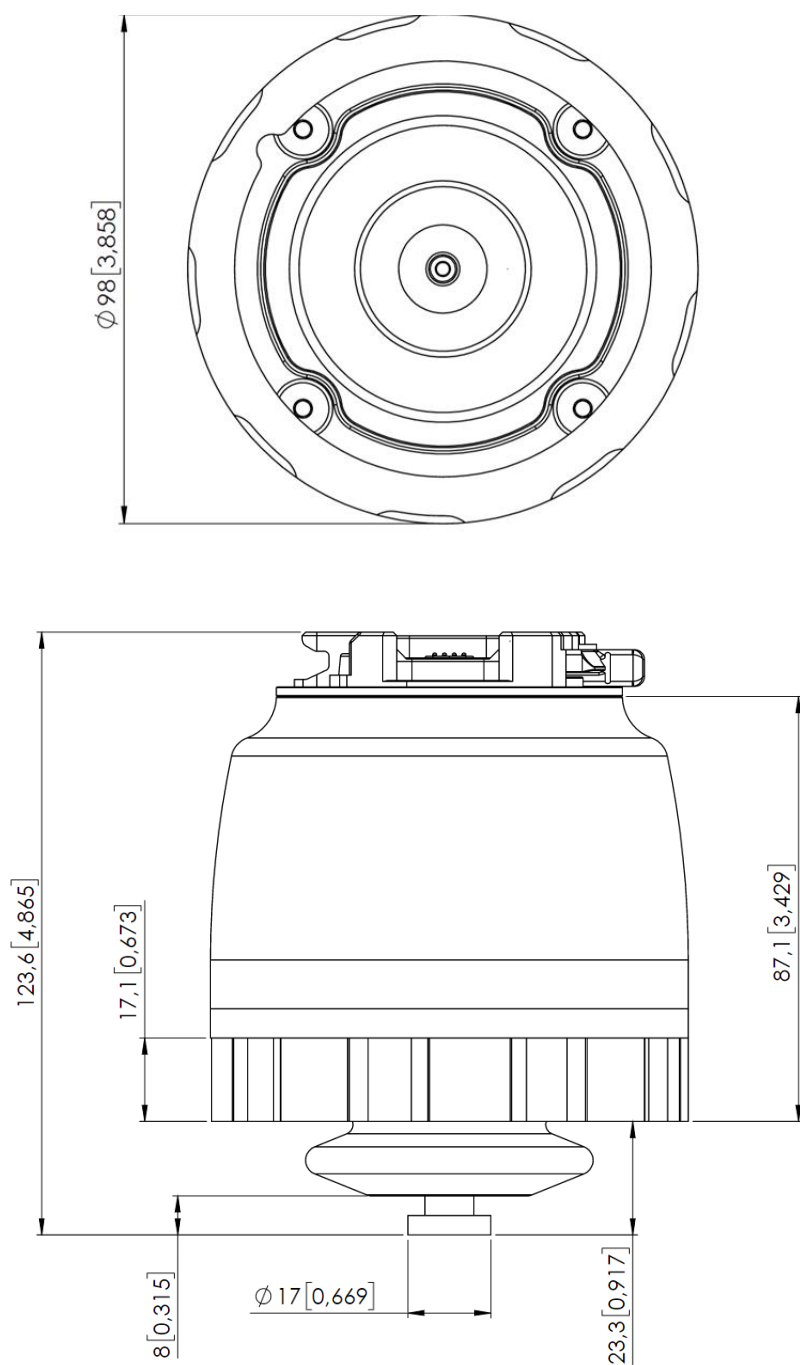

All dimensions are in mm and [inches].

## 1.2 SG Tools - general

The following SG tools are available:

- SG-a-H
- SG-a-S
- SG-b-H

The letter a and b show the size and shape of the tool and the letter H and S shows whether the tool is Hard (H) or Soft (S)

General Properties	Minimum	Typical	Maximum	Unit
Material	Two-component silicone rubber			
Food approval	FDA 21 CFR 177.2600* & EC 1935/2004			
Operation cycles	2.000.000	-	-	[cycles]
Storage temperature	0 32		60 140	[C] [F]
Operation temperature	-20 -4		80 176	[C] [F]
SG-tool attachment mechanism	Quick-lock and Smart-lock			
Washable	Dishwasher safe			

\* Tested and approved for non-fatty food objects.

### 1.3 SG-a-S/H

The S and the H variants are identical except the very end of the tool (C) that is Soft in case of the S variant.

Properties	Minimum	Typical	Maximum	Unit
Max payload SG-a-H/SG-a-S	-	-	2.2/1.5* 4.85/3.3	[kg] [lb]
Gripping time	0	-	32	[Grip/min]
Work range Grip dimensions (A)	11 0.43	-	75 2.95	[mm] [inch]
Work range Grip depth (B)	-	38 1.496		[mm] [inch]
Soft part (SG-a-S) (C)		16 0.63		[mm] [inch]
Dimensions (H x Ømax)	76 x 112 3 x 4.4			[mm] [inch]
Weight (smart-lock included)	0.168 0.37			[kg] [lb]

\* Test object: 3D-printed ABS cylinder Ø65mm. Payload depends on shape, softness and friction of the product.

#### Work Range

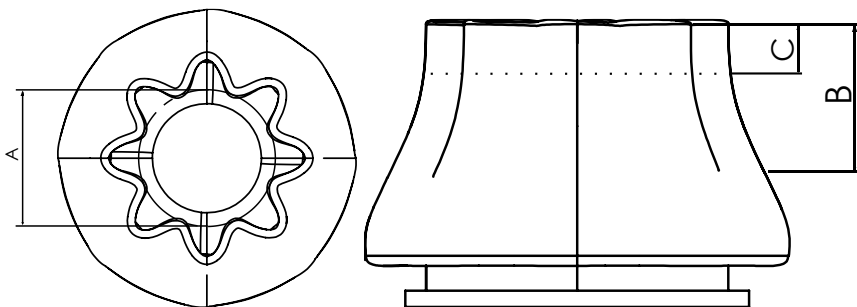

#### SG tool dimensions

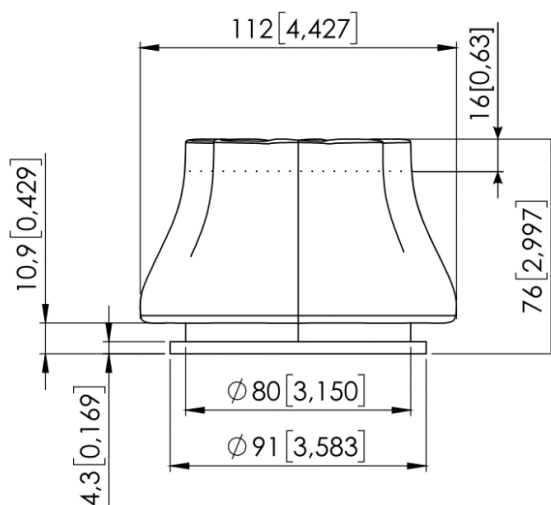

All dimensions are in mm and [inches].

**SG-a-H Workpiece examples**

The table below shows a list of differently shaped workpieces picked with an SG-a-H tool, they all share the same grip width, roughness and fragility.

Workpiece	Dimensions [DxH]	Payload
Cylinder	65mm x 30mm	2.2kg
Hexagon	65mm x 30mm	1.8kg
Equilateral triangle	65mm x 30mm	0.7kg
Round	65mm	0.5kg
Ellipse	65mm x 30mm	1.0kg
Square	65mm x 30mm	N/A
Cylinder / Round stick	30mm x 65mm	1.6kg

Test object material: 3D-printed ABS

**Center of Gravity**

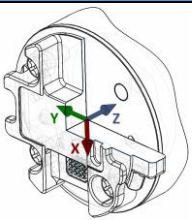
Coordinate system	TCP [mm]	Center of Gravity [mm]	Weight*
	X=0 Y=0 Z=154	cX=-12 cY=-5 cZ=45	0.932 kg 2.05 lb

\*Including the SG base unit.

### 1.4 SG-b-H

Properties	Minimum	Typical	Maximum	Unit
Max payload*	-	-	1.1 2.42	[kg] [lb]
Gripping time	0	-	32	[Grip/min]
Work range Grip dimensions (A)	24 0.94	79 3.1	118 4.65	[mm] [inch]
Work range Grip depth (B)	-	40 1.57		[mm] [inch]
Dimensions (H x Ømax)	77x109 3.03 x 4.29			[mm] [inch]
Weight (smart lock included)	0.172 0.379			[kg] [lb]

\*Test object: 3D-printed ABS cylinder Ø30mm (horizontal workpiece). Payload depends on shape, softness and friction of the product.

#### Work range

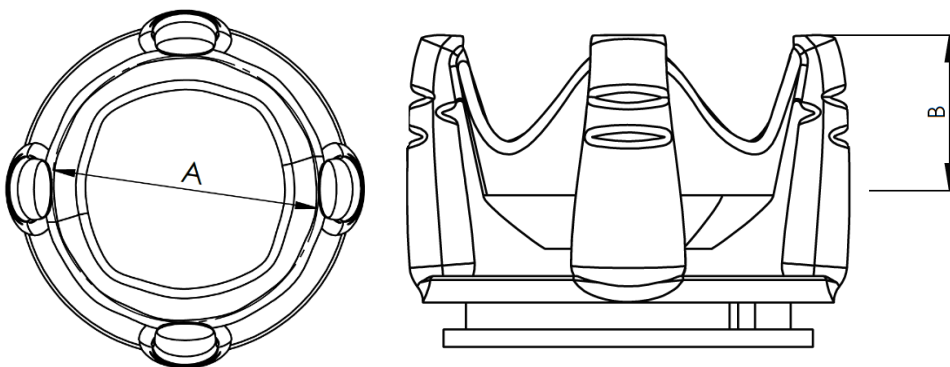

#### SG tool dimensions

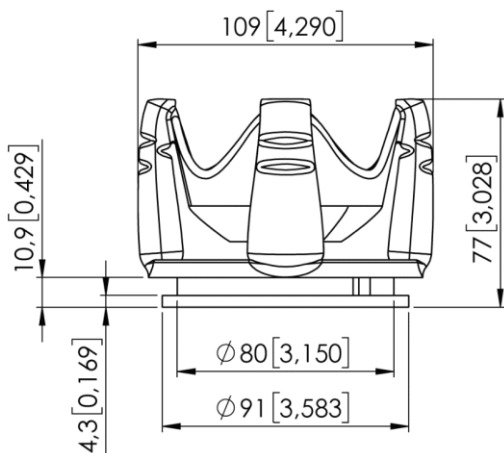

All dimensions are in mm and [inches].

**Workpiece examples**

The table below shows a list of differently shaped workpieces picked with an SG-b-H, they all share the same grip width, roughness and fragility.

Workpiece	Dimensions (DxH)	Payload
Cylinder	65mm x 30mm	0.6kg
Hexagon	65mm x 30mm	0.5kg
Equilateral triangle	65mm x 30mm	N/A
Round	65mm	1.0kg
Ellipse	65mm x 30mm	0.3kg
Square	65mm x 30mm	0.5kg
Cylinder / Round stick	30mm x 65mm	1.1kg

Test object material: 3D-printed ABS

**Center of Gravity**

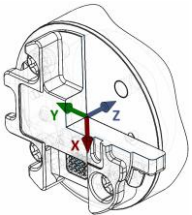
Coordinate system	TCP [mm]	Center of Gravity [mm]	Weight*
	X=0 Y=0 Z=155	cX=-12 cY=-5 cZ=46	0.937 kg 2.06 lb

\*Including the SG base unit.



### 1.4.1 How to handle a workpiece

With the elastic silicone SG tools, the gripper can handle a wide range of workpieces, for a high number of applications. Different tool designs have some overlap in capability when handling the same workpiece, but the tools have different characteristics and do have individual effectiveness on a given workpiece.

#### Soft silicone

Some SG tool designs has a soft silicone part in the top of the gripper. These tools are better suited for handling fragile workpieces and/or workpieces with a high variance in size, compared to the hard silicone tools. This is due to the more "forgiving" nature of the soft part. The user may experience a reduced payload compared to the hard silicone tools.

To handle a workpiece properly, the user must know some parameters that are defined by the general conditions of the workpiece and its presentation in the application. This helps to define which tool to choose and the actual grip width on it.

A general overview of such parameters is listed below:

- Shape
- Dimension
- Weight
- Roughness
- Fragility
- Orientation of pick/placement

For a better understanding of how to handle workpieces with different parameters, tests were conducted with a SG-a-H tool, see table below.

Example of material	Workpiece	Dimension	Weight	Roughness	Shape	Actual gripping width
Smooth wood (Sanded)	Round stick	27mm	32g	5	Cylinder	20mm
Polished metal	Aluminum cube	35x25mm	512g	1	Square	15mm
Rough metal	Aluminum cylinder	60mm	490g	8	Cylinder	55mm
Plastic	PET Bottle	65mm	431g	1	Cylinder	50mm
	POM-C	50mm	221g	2	Cylinder	42mm
	POM-C	50mm	1410g	2	Cylinder	15mm
Glass	Drinking glass	68mm	238g	1	Cylinder	50mm
Organic material	Tomato	54mm	92g	2	Round	53mm
	Mushroom	40mm	8g	10	Round	39mm
	Grape	20mm	7g	10	Oval	16mm
Carbonfiber	Carbonfiber cylinder	38mm	48g	7	Cylinder	29mm

Notice objects with high weight needs higher force asserted upon them, therefor the small gripping width.

**NOTE:**

The results shown in the table above, should be considered as indicative and may vary. The actual grip width always require testing, for verification.

It is often a good idea to set a target width smaller, than actual workpiece width, to reach a higher surface contact area and to accommodate for vibrations and other unexpected conditions.

For heavy and large workpieces test at low velocity and with caution.

**NOTE:**

For individual SG-tool examples. See the separate SG-tool manual.

The criteria for roughness are a basic scale from 1-10, here are the benchmarks used to determine the values.

Roughness	Description	Example
1	Polished/Smooth	Polished Metal
5	Textured	Cardboard
10	Rough	Sandblasted Metal

**WARNING:**

Sharp edges, on a workpiece, may damage the silicone and reduce lifetime of the tool.

# MACHINETOOL

Oy Machine Tool Co  
Teerikukonkuja 4, 00700 Helsinki  
09 351951  
www.machinetool.fi