

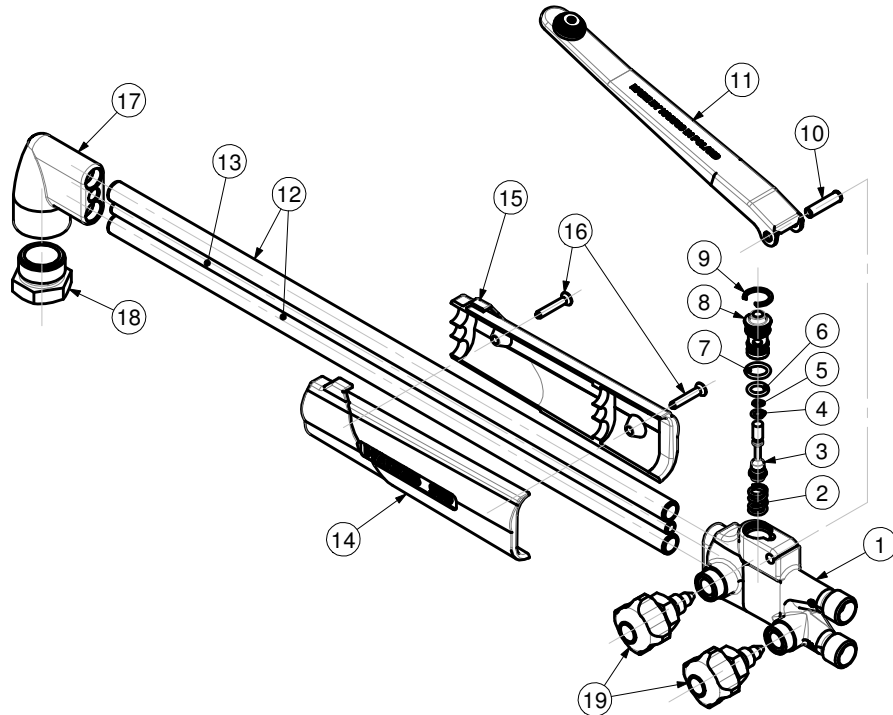

HAND CUTTING TORCH -MODEL 980NM

PART NUMBER / DESCRIPTION		
Item	1	
MODEL No.	TAIL	Screw thread
980NM	88088	9/16"-18-UNF
980NMGB	880882	G 3/8"



ITEM	PART No.	Qty	DESCRIPTION	ITEM	PART No.	Qty	DESCRIPTION
1	See Table	1	Tail	11	D980	1	Lever
2	88085	1	Spring	12	880922	2	Tube
3	88066	1	Plunger	13	88092	1	Tube
4	215X715105A	1	O-Ring	14	98043L	1	Front casing
5	215X715178A	1	O-Ring	15	88043R	1	Back casing
6	215X715052A	1	O-Ring	16	880772	2	Screw
7	215X715612A	1	O-Ring	17	88044	1	Head
8	88042	1	Guide	18	4559	1	Nut
9	880X71	1	Retaining ring	19	A142GBPS	2	Valve
10	24261	1	Roll pin				

SERVICE NOTES

ITEM No.	TORQUE SPECIFICATION	SERVICE TOOL OR NOTES
1		52T2R - To reseal oxygen hose connection for tail 88088
		52T3R - 9/16"-18-UNF-RH - Die oxygen hose threads for tail 88088
		52T2L - To reseal fuel hose connection for tail 88088
		52T3L - 9/16"-18-UNF-LH - Die fuel hose threads for tail 88088
		RT860104 - To reseal oxygen hose connection for tail 880882
		43ETR - G 3/8" A-RH - Die oxygen hose threads for tail 880882
		RT84357SL - To reseal fuel hose connection for tail 880882
		43ETL - G 3/8" A-LH - Die fuel hose threads for tail 880882
		62T9 - 9/16"-27-UNS-RH - Die for needle valve threads
	RT14288 - To reseal needle valve	
	13T2 - 3/8"-24-UNF-RH - Tap for needle valve threads	
4 - 5 - 6 - 7		Use Molykote M-55
9		RT8801 - Retaining ring remover
16	1-1,2 Nm	Screw driver
17		R300T - To reseal tip seat
		5944T1 - 7/8"-20-UNEF-RH - Tap for tip nut threads
18		25mm open end wrench
19	12 Nm	17mm open end wrench - Use Molykote M-55

IMPORTANT: All repairs or conversions should be carried out by a qualified repairer, with genuine HARRIS parts, to HARRIS repair specifications, and in accordance with local laws or regulations. No contaminant (grease, oil, others) to come in contact with oxygen.

TAB.980NM-001