

EdmoLift nostovaunut



Made in Sweden

ERGONOMIC LIFT TROLLEYS FOR PRODUCTION, OFFICE AND RETAIL

With our lift trolleys, heavy and strenuous lifting is avoided which minimises the risk of work injuries caused by repeated lifting, moving and handling of heavy objects.



EDMOLIFT WP LIFTING TROLLEYS FOR WEIGHTS UP TO 300 KG

Work Positioners facilitate lifts and transport of goods in most industries. Our lifting trolleys are available in many different designs, with a wide range of accessories and options to customise them to meet your specific requirements. The lifting trolleys made of stainless steel and the WP By EdmoLift series can be specifically adapted to suit your particular needs.

WP ONE – UP TO 70 KG

The WP ONE stands out with its outstanding manoeuvrability, intuitive control unit and low price.

WP BY EDMOLIFT – UP TO 200 KG

The lifting trolleys in the WP By EdmoLift series effectively handle weights of up to 200 kg and are designed with the best ergonomics and flexibility in mind. The WP By EdmoLift series distinguishes itself with its versatile adaption options, the robust design and outstanding manoeuvrability.

STAINLESS STEEL SERIES – UP TO 300 KG

The lifting trolleys in the stainless steel series effectively handle weights of up to 300 kg and are designed with the best ergonomics and flexibility in mind.



Work Positioner - WP ONE

The WP ONE has been masterfully designed to fit the most common and important usage areas and at the same time be offered at a very low price. The WP ONE allows the operator to place, position, move and remove the load in a simple, safe and sturdy fashion. The WP ONE comes with the best-selling wooden platform, made of marine plywood, and has countless areas of usage in almost any setting. The WP ONE is delivered in one single cardboard box. You just take it out, follow the few simple steps in the quick guide and you have your WP ONE up and running in no time. We keep the WP ONE in storage, always ready for instant delivery!

BOX CONTENT

- ▶ Mast with motor
- ▶ Handle with control unit
- ▶ Wooden platform
- ▶ Legs
- ▶ Charger
- ▶ Assembly kit for easy self-assembly with 12 fasteners
- ▶ User manual
- ▶ Quick guide



Handle with control unit

Model	Art. no.	Capacity kg	Max platform height mm	Lowest height mm	Length mm	Width mm	Height mm	Platform LxW mm	Lift time mm/sec	Batteries	Charger	Weight kg	Note
▶ WP ONE	89503	70	1505	120	846	379	1700	434 x 418	125	24V 7,2Ah	2A/24V	30	

Price includes: Charger and wooden platform (LxW 434x418 mm).

Lift capacity valid for evenly distributed load.

Get started in three easy steps

STEP 1
Attach the legs

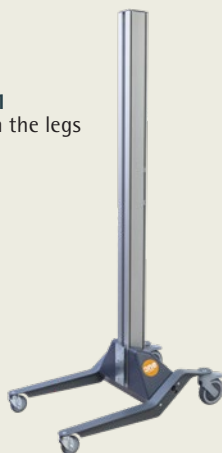

STEP 2
Attach the handle



STEP 3
Attach the platform and the WP ONE is ready to go



Tools and options - WP ONE

Wooden platform (included)

Dimensions LxW 434x418 mm.

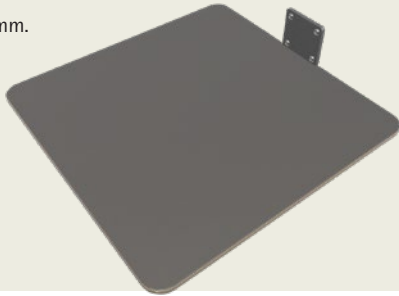

Reel mandrel

Length 500 mm, 40x40 mm.



Art. no.: 614744 **WP ONE**

Canister tipper 25 liter

Designed for standard size 15, 20 and 25 liter canisters. The canister is attached to the carrying handle with a hook. Lifts and rotates the canister to empty its content. Rotation 360° with adjustable interval of 30° or 90°. Lift capacity 40 kg.



Art. no.: 89481 **WP ONE**



Work Positioners - WP by EdmoLift



POWERFUL WORK POSITIONERS DESIGNED FOR HEAVY LIFTING

The Swedish-made lift trolleys in the WP by EdmoLift series have been developed to provide the operator with the opportunity to easily lift, transport, and position heavy objects, all under perfect ergonomic conditions. With lift capacities up to 200 kgs, the powerful lift trolleys in the new WP by EdmoLift series have many areas of usage while the design of the trolleys entails unbeatable mobility and ergonomics. With the many accessories available, the WP by EdmoLift series offers you the market's most universal and solid lift trolleys that can be easily adjusted to fit your needs.

MAST AND LIFT FUNCTION

The mast is made up of anodised aluminium with a steel sledge with precision ball bearings, the

lifting trolleys are fitted with strong energy-efficient 24VDC motors and powered by a steel reinforced belt that does not need any special maintenance.

CONTROL UNIT

The lift trolleys are fitted with soft start and stop for safe and precise load handling, they are easy to use with a distinct button on the control unit.

SAFETY

All parts are shielded. The lift has overload protection and safety circuit. The lifters are supplied with a smart charger which automatically stops charging the battery once it is fully charged.

PRODUCT FEATURES

- ▶ The market's fastest lifting speed – 125 mm/sec
- ▶ Outstanding manoeuvrability
- ▶ Soft start and stop
- ▶ Silent operation
- ▶ Wide range of tools and options such as platforms, canister tippers, v-cradles and control units.
- ▶ Operationally reliable - steel reinforced belt instead of chain
- ▶ See page 81-87 for stainless alternatives



Easy to use control unit with battery indicator

Work Positioners - WP by EdmoLift

► Other leg frames are available upon request.



WP 130

WP 130EM

WP 200

WP 200EM

Model	Art. no.	Capacity kg	Max platform height mm	Lowest height mm	Length mm	Width mm	Height mm	Platform LxW mm	Lift time mm/sec	Batteries	Charger	Weight kg	Note
WP 130	87674-BE	130	1690	110	865	535	1915	500 x 500	125	24V 9Ah	2A/24V	61	
WP 130EM	87675-BE	130	2090	110	865	535	2315	500 x 500	125	24V 9Ah	2A/24V	63	
WP 200	87677-BE	200	1690	110	874	535	1970	500 x 500	125	24V 9Ah	3A/24V	65	
WP 200EM	87678-BE	200	2090	110	874	535	2370	500 x 500	125	24V 9Ah	3A/24V	67	

Prices include: Charger and platform in painted aluminium 614773. When selecting a different tool, the price for the included tool is deducted from the total price.

Lift capacity valid for evenly distributed load. All models can be delivered in conductive execution.

Tools and accessories for Work Positioners - WP by EdmoLift

Platform in painted aluminium

Standard platform, dimensions LxW 500x500 mm, available in other dimensions.



Art. no.: 614773 WP 130 WP 200

Platform in painted steel

Dimensions LxW 500x500 mm, available in other dimensions.



Art. no.: 614769 WP 130 WP 200

Platform in stainless steel

Dimensions LxW 500x500 mm, available in other dimensions.



Art. no.: 614768 WP 130 WP 200

Tools and accessories for Work Positioners – WP by EdmoLift

Reel mandrel

Length 500 mm, 40x40 mm, available in other dimensions.

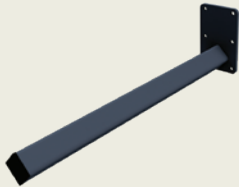

Art. no.: 614744 **WP 130** **WP 200**

Twin mandrel

Length 500 mm, c-c 350 mm, available in other dimensions.

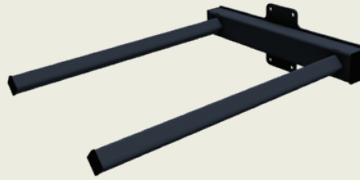

Art. no.: 614784 **WP 130** **WP 200**

Jib arm

Length 600 mm, lift capacity varies depending on load's position, available in other dimensions.



Art. no.: 614746 **WP 130** **WP 200**

Lifting fork

Internal measurements LxW 600x375 mm, available in other dimensions.

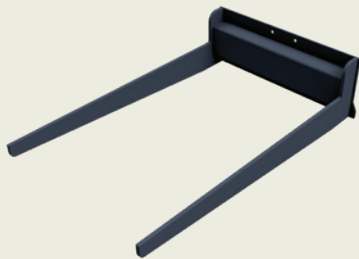

Art. no.: 614782 **WP 130** **WP 200**

Lifting fork KLT

For KLT containers with narrow receiving edge. Internal measurements LxW 585x375 mm.

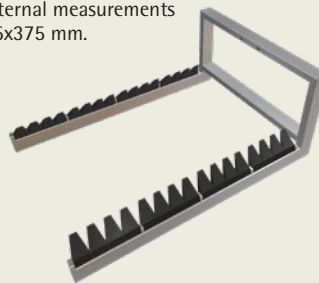

Art. no.: 87416 **WP 130**

Plastic platform

Dimensions LxW 495x495 mm, available in other dimensions.

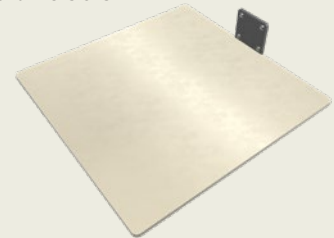

Art. no.: 87364 **WP 130**

Plastic platform with 3 load rollers

Dimensions LxW 495x495 mm, also available with wooden platform.

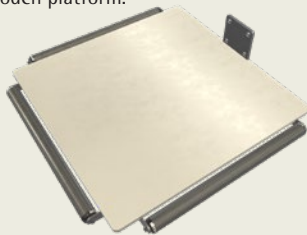

Art. no.: 87366 **WP 130**

Platform in stainless steel + V-cradle

Platform in stainless steel, V-cradle made of plastic LxWxH 340x290x80 mm, max. width of reel Ø600 mm, lift capacity 90 kg.

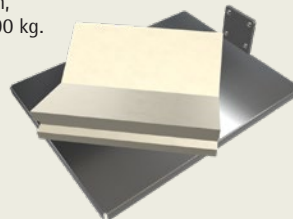

Art. no.: 87412 **WP 130**

Reel mandrel with front roller and V-cradle

Max. width of reel Ø600 mm, lift capacity 60 kg

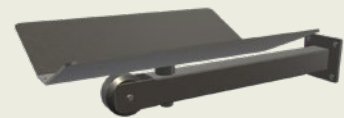

Art. no.: 87371 **WP 130**

Fixed V-cradle

For long reels, dimensions V-cradle LxW 400x700 mm, lift capacity 100 kg.

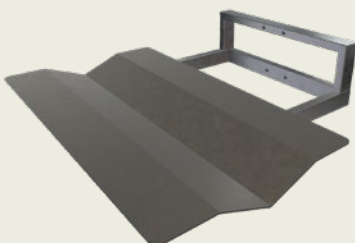

Art. no.: 87725 **WP 130**

Flex unit base

The two sledges are steplessly adjustable to fit the width of the object that needs to be handled. Reel mandrels, lifting forks and crane arms are mounted on the base unit, not included in the price. Max. width 588 mm, min. width 210 mm. Lift capacity 100 kg.



Art. no.: 89569 **WP 130**

Quick release bracket

Part for the sledge and part for the tool



87798 & 87797

Part for sledge, art. no.: 87798 **WP 130**

Part for tool, art. no.: 87797 **WP 130**

Part for sledge, art. no.: 89376 **WP 200**

Part for tool, art. no.: 89375 **WP 200**

Tools and accessories for Work Positioners - WP by EdmoLift

Manual turning unit

Makes fixed tools rotatable. Rotation 360° with adjustable interval of 30° or 90°. Desired tool is mounted on the turning unit, not included in the price. Lift capacity 60 kg.

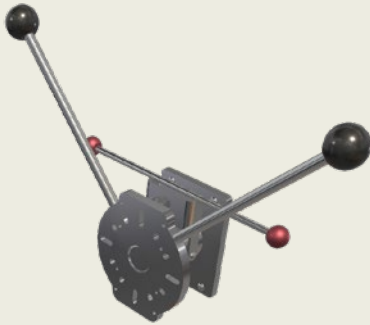

Art. no.: 89477 WP 130

Canister tipper 60 liter

Designed for standard size 60 liter canisters. The canister is attached to the carrying handle with a hook. Lifts and rotates the canister to empty its content. Rotation 360° with adjustable interval of 30° or 90°. Lift capacity 80kg.



Art. no.: 89568 WP 130

Bucket and drum handler

Lifts odd size drums, buckets and cans, min Ø200 mm, max Ø400 mm. Can also handle square items depending on the specific object. Automatic retracting lashing strap which is tightened by pulling the handle by the lashing strap. Rotation 360° with adjustable interval of 30° or 90°. Lift capacity 50 kg.

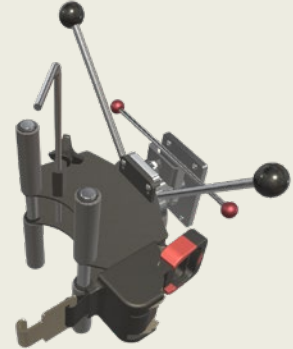

Art. no.: 89480 WP 130

Control unit

With buttons in the handle, vertically adjustable.



Art. no.: 87733 WP 130 WP 200

Control unit

With spiral cable, dual speed 125 or 60 mm/second.



Art. no.: 87730 WP 130 WP 200

Arrow and stickers

For level adjustment, the arrow is fixed on the sledge and the stickers on the mast, used for quick height indication.



Art. no.: 87734 WP 130 WP 200

More tools (only compatible with other types of WP)

Reel handler

Rotatable 90°, swing ±15°, for reels with cores of 3" (76 mm), max Ø800 mm, max. length of reel 500 mm, lift capacity 80 kg.



Exchangeable battery with quick swap

Includes wall mounted charger station and two batteries 24V/9Ah.

Work Positioners with electrical tools

We also offer Work Positioners with motorized grip, rotation and expansion that are available for various applications and can be equipped with different types of grippers depending on the application. Contact EdmoLift for more information.



Drum turner 87924 with motorized grip and rotation

Stainless Steel Work Positioners



STAINLESS STEEL WORK POSITIONERS DESIGNED FOR FOOD AND PHARMA INDUSTRY

The lifting trolleys in the stainless steel series effectively handle weights of up to 300 kg and is designed with the best ergonomics and flexibility in mind. The entire series can be specially adapted to suit your specific needs.

The models WP 90 SS, 200 SS and 300 SS are designed in AISI 304 stainless steel and are IP66 classified, which makes them completely immersible. The WP 70 SS models are semi-stainless with mast in aluminium, leg and handle in stainless steel. These models cannot be flushed.

The products are designed for use in confined spaces. By handling heavy loads with a lifting motion where as little muscle power as possible is used, the risk of injuries caused by repetitive lifting, moving and handling of heavy objects is minimised.

The lifting trolleys in the stainless series distinguish themselves with its versatile adaption options, robust design and outstanding manoeuvrability.

CONTROL UNIT

WP 90 SS, 200 SS and 300 SS models are equipped with soft start and stop as well as control unit with two speeds.

MAST AND LIFT FUNCTION

The mast has a stainless steel sledge with precision ball bearings, the lifting trolleys are fitted with strong energy-efficient 24VDC motors and powered by a steel reinforced belt that does not need any special maintenance.

SAFETY

All parts are shielded. The lift has overload protection and safety circuit. The lifters are supplied with a smart charger which automatically stops charging the battery once it is fully charged.

PRODUCT FEATURES

- ▶ Electro polished stainless steel and semi-stainless models
- ▶ The market's fastest lifting speed – 125 and 200 mm/second
- ▶ Outstanding manoeuvrability
- ▶ Soft start and stop
- ▶ Silent operation
- ▶ Wide range of tools and options such as platforms, reel handlers, v-cradles, control units and leg frames.
- ▶ Operationally reliable – steel reinforced belt instead of chain.
- ▶ Two lifting speeds, WP 90 SS, 200 SS and 300 SS



Control unit for WP 70 SS models



Control unit for WP 90 SS Q, 200 SS models

Stainless steel work positioners

► Other leg frames are available upon request.



WP 70 SS



WP 90 SS Q



WP 200 SS

Model	Art. no.	Capacity kg	Max platform height mm	Lowest height mm	Length mm	Width mm	Height mm	platform LxW mm	Lift time mm/sec	Batteries	Charger	Weight kg	Note
WP 70S SS*	87686	70	1051	101	747	560	1217	495 x 495	125	24V 7,2Ah	1,8A/24V	29	
WP 70 SS*	87687	70	1346	101	747	560	1512	495 x 495	125	24V 7,2Ah	1,8A/24V	30	
WP 70EM SS*	87688	70	1746	101	747	560	1912	495 x 495	125	24V 7,2Ah	1,8A/24V	32	
WP 90S SS Q	87761	90	1015	128	746	550	1221	495 x 495	100/200	24V 9Ah	1,8A/24V	41	
WP 90 SS Q	87689	90	1304	128	746	550	1516	495 x 495	100/200	24V 9Ah	1,8A/24V	44	
WP 90EM SS Q	87690	90	1710	128	746	550	1918	495 x 495	100/200	24V 9Ah	1,8A/24V	47	
WP 200S SS	87679	200	1280	80	899	550	1610	500 x 400	125	24V 18Ah	1,8A/24V	67	
WP 200 SS	87680	200	1650	80	899	550	1980	500 x 400	125	24V 18Ah	1,8A/24V	71	
WP 200EM SS	87681	200	2080	80	899	550	2410	500 x 400	125	24V 18Ah	1,8A/24V	76	
WP 300 SS	87682	300	1415	126	1120	580	1970	600 x 600	125	24V 18Ah	3A/24V	105	
WP 300EM SS	87683	300	1765	126	1120	580	2320	600 x 600	125	24V 18Ah	3A/24V	115	

Charger included. All models can be delivered in conductive execution.
*Semi-stainless, most in aluminium
Lift capacity valid for evenly distributed load.

The prices include: plastic platform 87796 for WP 70 SS and WP 90 SS, platform in stainless steel 87613 for WP 200 SS and platform in stainless steel 87892 for WP 300 SS. When selecting a different tool, the price for the included tool is deducted from the total price.

Tools and accessories for stainless steel Work Positioners

Platform in stainless steel

Dimensions LxW 500x500 mm (WP 300 LxW 570x380 mm), available in other dimensions.



Art. no.: 87793 WP 70 WP 90
Art. no.: 87613 WP 200
Art. no.: 87620 WP 300

Plastic platform

Dimensions LxW 495x495 mm, available in other dimensions.

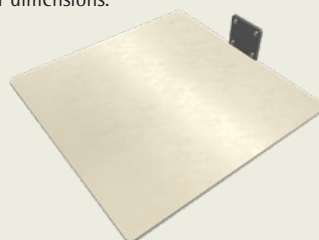

Art. no.: 87796 WP 70 WP 90

Plastic platform with 3 load rollers

Dimensions LxW 495x495 mm.

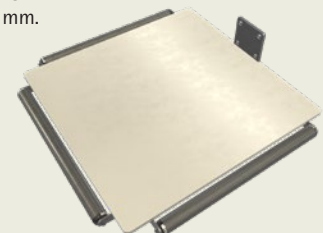

Art. no.: 87794 WP 70 WP 90

Tools and accessories for stainless steel Work Positioners

Flex unit base

The two sledges are steplessly adjustable to fit the width of the object that needs to be handled. Reel mandrels, lifting forks and crane arms are mounted on the base unit, not included in the price. Max. width 588 mm, min. width 210 mm. Lift capacity WP 70=50 kg, WP 90=70 kg.



Art. no.: 89569 WP 70 WP 90

Reel mandrel

Length 500 mm, Ø60 mm, available in other dimensions. Customized length for WP 300, max. 800 mm.



Art. no.: 87792 WP 70 WP 90

Art. no.: 87616 WP 200

Art. no.: 87898 WP 300

Twin mandrel

Length 500 mm, c-c 250 mm (WP 200 c-c 300 mm), available in other dimensions.

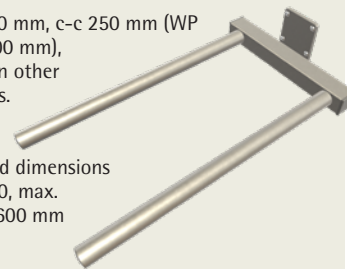

Customized dimensions for WP 300, max. LxW 800x600 mm

Art. no.: 87790 WP 70 WP 90

Art. no.: 87617 WP 200

Art. no.: 87900 WP 300

Lifting fork

Internal measurements LxW 585x375 mm (WP 200 LxW 570x380 mm), available in other dimensions.

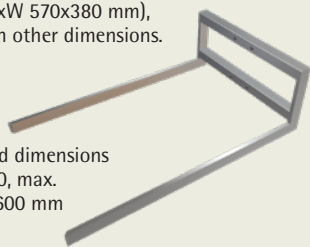

Customized dimensions for WP 300, max. LxW 800x600 mm

Art. no.: 87787 WP 70 WP 90

Art. no.: 87614 WP 200

Art. no.: 87901 WP 300

Lifting fork KLT

For KLT containers with narrow receiving edge. Internal measurements LxW 585x375 mm.

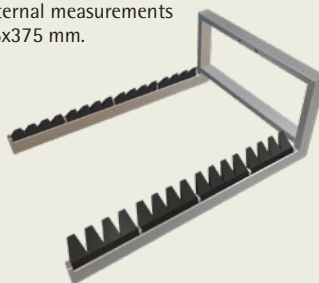

Art. no.: 87416 WP 70 WP 90

Reel mandrel with front roller and V-cradle

Max. width of reel Ø600 mm, lift capacity WP 70=30 kg, WP 90=60 kg.



Art. no.: 87788 WP 70 WP 90

Reel handler

Rotatable 90°, swing ±15°, for reels with core of 3" (76 mm), max. Ø900 mm, max. length of reel 500 mm, lift capacity WP 80 and 90 = 50 kg, WP 130 = 80 kg, WP 200 = 100 kg.

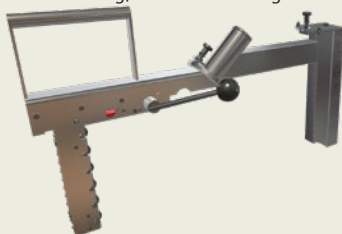

Art. no.: 87618 WP 90 WP 200

Jib arm with lifting hook

Length 600 mm, swing ±15° (WP 200 and WP 300 has no swing), Lift capacity depends of position of load. Available in other dimensions.

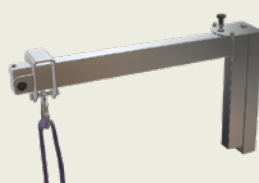

Art. no.: 87723 WP 90

Art. no.: 87619 WP 200

Art. no.: 87935 WP 300

Exchangeable battery with quick swap

Includes wall mounted charger station and two batteries 24V/9Ah.



Art. no.: 87759 WP 200

Manual turning unit

Makes fixed tools rotatable. Rotation 360° with adjustable interval of 30° or 90°. Desired tool is mounted on the turning unit, not included in the price. Lift capacity 60 kg.

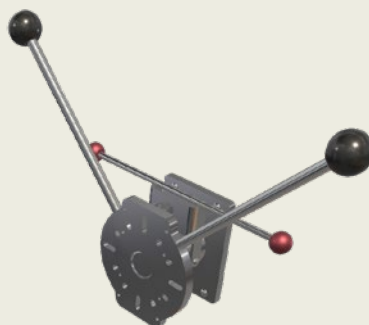

Art. no.: 89477 WP 70 WP 90

Tools and accessories for stainless steel Work Positioners

Quick release bracket

Part for the sledge and part for the tool

- Start kit*, art. no.: 89129 **WP 70**
- Part for tool, art. no.: 89130 **WP 70**
- Part for sledge, art. no.: 87798 **WP 90** **WP 130**
- Part for tool, art. no.: 87797 **WP 90** **WP 130**
- Part for sledge, art. no.: 89376 **WP 200**
- Part for tool, art. no.: 89375 **WP 200**

*includes two quick release bracket (89130) part for tool and one quick release part for sledge



87798 & 87797

The bracket for WP 70 has another design

Mandrel enlarger

For handling of reels with a core of 6" (152 mm), quick release bracket, fits reel rotator 87618. Other model available for reels with 10" (254 mm) core.

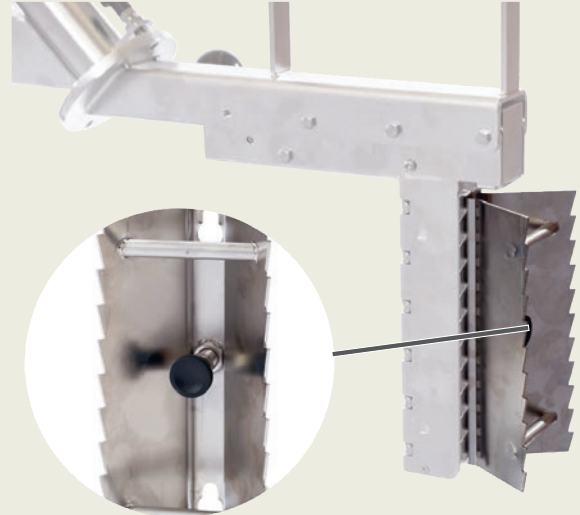

Art. no.: 87627 **WP 90** **WP 200** **WP 300**

Work Positioners with electrical tools

We also offer stainless steel Work Positioners with motorized grip, rotation and expansion that are available for various applications and can be equipped with different types of grippers depending on the application.

Contact EdmoLift for more information.



Reel handler 87923 with motorized expansion and rotation



Drum turner 87924 with motorized grip and rotation

Work Positioners for efficient handling of wheels

- ▶ Good ergonomics
- ▶ Higher working capacity
- ▶ Safe lifting

Wheel Lifter

The Wheel Lifter is designed for best ergonomics and efficiency when heavy wheels are to be lifted in or out of pallet racks. The lifter handles four wheels. The accessory Wheel Trolley is used to smoothly roll the wheels over the floor.

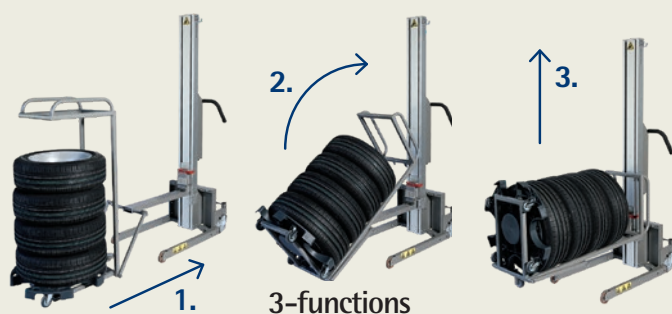

Model	Art.no.	Capacity kg	Lift height mm	Length mm	Width mm	Height mm	Lift time mm/sec	Batteries	Charger	Weight kg	Note
WP 130WL	88270	130	1710	1350	510	1990	125	24V 9Ah	2A/24V	80	

Wheel Mounting Lifter

The Wheel Mounting Lifter is designed for best ergonomics and efficiency when heavy wheels are to be mounted onto a vehicle. Loading wheels directly onto the forks makes it possible to rotate the wheels on the integrated load rollers to find the correct position for the wheel bolts. Two tires can be lifted at a time. The accessory Wheel Trolley makes it possible to lift a stack of 4 wheels directly from the floor to an ergonomic working height.



Model	Art.no.	Capacity kg	Lift height mm	Length mm	Width mm	Height mm	Lift time mm/sec	Batteries	Charger	Weight kg	Note
WP 130WM	88269	130	1235	750	750	1350	125	24V 9Ah	2A/24V	49	

Wheel Trolley - accessory

Used for easy wheel handling. The Wheel Trolley is designed to be used with the Wheel Lifter and the Wheel Mounting Lifter.



Art.no.	Accessory	Fits	Note
88282	Wheel Trolley, handles 4 wheels, one package contains 6 pcs of Wheel Trolleys.	WP 130WL, WM	