

Robot kit

ROB-SET FXCB UR O20

Part no.:10.01.43.00064

<https://www.schmalz.com/10.01.43.00064>

Homepage > Vacuum Technology for Automation > Vacuum Components > Area Gripping Systems and End Effectors > Vacuum Area Gripping Systems FXCB/FMCB > Handling Sets FXCB > ROB-SET FXCB UR O20

Complete vacuum system for connecting to lightweight robots



with: area gripper FXCB
for: Universal Robots
Type: 3,5,10,16

Design Data

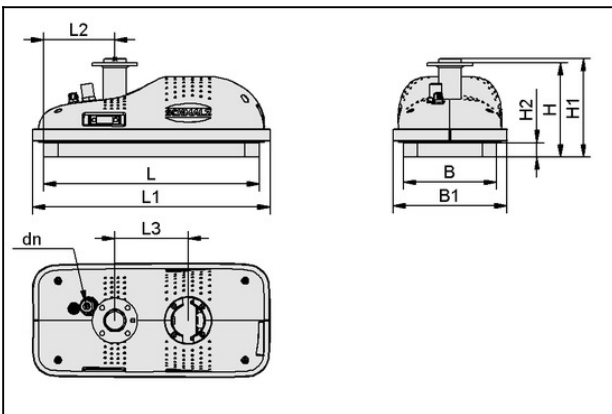

Attribute	Value
B	130 mm
B1	159 mm
H	131.4 mm
H1	137.4 mm
H2	20 mm
L	300 mm
L1	331 mm
L2	99 mm
L3	102 mm
dn	10 mm

Robot kit

ROB-SET FXCB UR O20

Part no.:10.01.43.00064

<https://www.schmalz.com/10.01.43.00064>



Technical Data

Attribute	Value
Weight	1.85 kg
Suction rate (max.)	525.9 l/min
Material type	Foam O, height 20 mm
Number of suction cells	45
Traglast (vertikal)	80 N
Max. load (horizontal)	350 N

The technical properties of the robot types may vary by region. The stated compatibility of the set is based on standard European models.

Spare Parts



MASK-FOL SW110 294 3R18 FLGR

Part no.10.01.11.03375

Front foil

Length L: 294 mm

Width B: 109.8 mm

Arrangement: 3 rows, 18mm

Shape: flow resistors

Nozzle diameter: 1.1 mm

for: Large-area vacuum gripper

Robot kit

ROB-SET FXCB UR O20

Part no.:10.01.43.00064

<https://www.schmalz.com/10.01.43.00064>



EMVP 2.35 24V-DC 2x3/2 NO/NC CAR

Part no.10.01.11.03420

Solenoid valve EMVP for vacuum, pneumatic pilot control

Nominal size: 2.35 mm

Voltage: 24V - DC

Function: 2x 3/2-way valve

Control: Optionally NO/NC

Pressure range (operating pressure):

3.00 ... 7.00 bar

Shape: Cartridge

Nominal flow rate: 15 m³/h

Weight: 0.064 kg

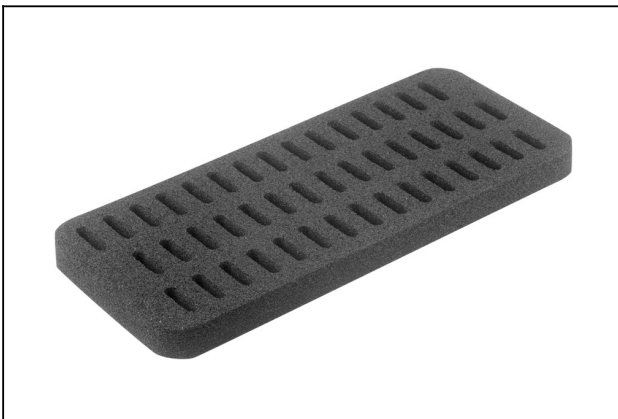

DI-PL 300x130 3R18 LL-20x7 O20 KE

Part no.10.01.11.03658

Sealing plate (FXCB/FMCB)

Length L: 300 mm

Width B: 130 mm

Arrangement: 3 rows, 18mm

Cell size: slot 20x7mm

Material-Type: Foam O, Height 20 mm

with: Adhesive tape on one side

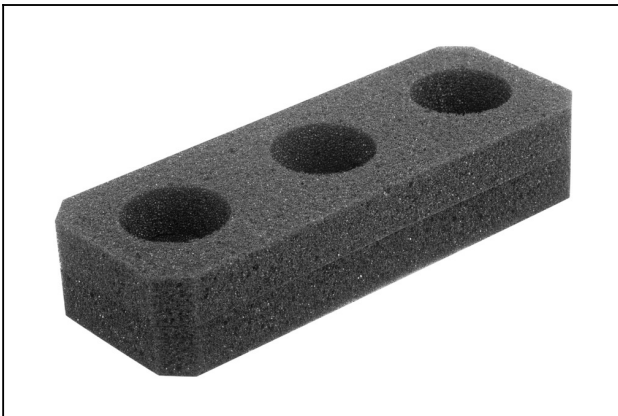

SD 97x34x20 FXCB

Part no.10.01.43.00005

Silencer for vacuum generators

Length L: 97 mm

Width B: 34 mm

Height H: 20 mm

for: area gripper FXCB

Robot kit

ROB-SET FXCB UR O20

Part no.:10.01.43.00064

<https://www.schmalz.com/10.01.43.00064>



VSi V D M8-4

Part no.10.06.02.00577

Vacuum and pressure switch with two digital output signals and IO-Link function

Measuring range: -1...0 bar

Type: with display

Electrical connection:

Male connect M8, 4 pole

Indication: 2xLED

Protection: IP 65

Accessories



VSL 10-7 PU

Part no.10.07.09.00084

Hose for vacuum and compressed-air systems

External diameter D: 10 mm

Internal diameter d: 7 mm

Length (max): 50 m

Material: PU

Installation radius (min): 60 mm

Colour: Transparent

Pressure range (operating pressure):

-0.95 ... 10.00 bar

Ambient temperature: -40 ... 85 °C